

The users should read this manual thoroughly before operation and observe the operating method and precautions for more effective operation.

MARINE TRANSMISSION

SERVICE MANUAL

MODEL

DMTP 6500

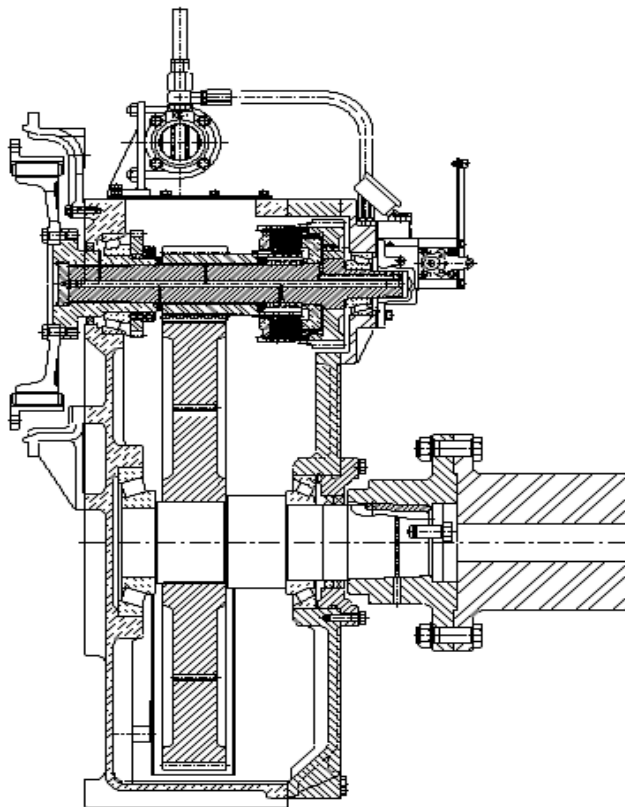

© D-I INDUSTRIAL CO., LTD.





Introduction

This manual contains the description of construction, operation principle, correct operation and handling method, precaution for installation, repair check, and etc. on D-I Marine transmission(DMTP6500).

APPLICATION	HYDRAULIC MARINE TRANSMISSION FOR MARINE APPLICATION
MODEL	DMTP6500
<p>The users should read this manual thoroughly before operation and observe the operating method and precautions. Keep this manual at a designated place for next time.</p>	

Before operation, users should read the contents \triangle marked in this manual. Since the contents \triangle marked are very important for safety, users should follow the instruction.

In this manual, DANGER degrees, which can occur by faulty treatment of users, are divided as following table.

 DANGER	If the contents \triangle marked are ignored, an urgent situation where people receive severe injure or die can be happened.
 CAUTION	If the contents \triangle marked are ignored, it can be the cause of death or sever injure and the cause of material damage.
 IMPORTANT	If the contents \triangle marked are ignored, it can be the cause of material damage.
	Important contents of this manual which should be observed.

CONTENTS

SECTION 1	- - - - -	INTRODUCTION
SECTION 2	- - - - -	CONSTRUCTION
SECTION 3	- - - - -	PRINCIPLES OF OPERATION
SECTION 4	- - - - -	HYDRAULIC SYSTEM
SECTION 5	- - - - -	INSTALLATION
SECTION 6	- - - - -	OPERATION
SECTION 7	- - - - -	PREVENTIVE MAINTENANCE
SECTION 8	- - - - -	TROUBLE SHOOTING
SECTION 9	- - - - -	DISASSEMBLY AND ASSEMBLY
OPTION	Live P.T.O.	
ANNEX I	PERIODIC INSPECTION TABLE	
ANNEX II	PARTS ORDER SHEET	
ANNEX III	WARRANTY LETTER	

SECTION 1 – INTRODUCTION.

1-1. OVERVIEW

The D-I marine transmission described in this manual are power transmission unit for ships, which transmits the power generated from engine into the propeller.

The major functions are ahead, neutral, astern in propulsion and certain rate of speed reduction, and it consist of the structure to support the thrust force generated from the propulsive force of propeller.

Additionally, a Power Take Off (Live P.T.O) is equipped in the marine transmission, which enables to drive a hydraulic pump.

The ahead and astern operation of marine transmission is transmitted by a pair of hydraulic multiple clutches and the necessary hydraulic system for it is built-in the marine transmission.

1-2. SPECIFICATIONS

Model	Reduction ratio	Max. Input speed (rpm)	Max. Input torque (kg-m)	Pressure (kg/cm ²)		Dry Weight (kg)	Flow of cooling water (ℓ/min)
				Operating oil	Lub. oil		
DMTP6500	5.11, 5.62, 5.91	2,400	258.6	20~26	2~4	850	40~60
	6.57, 6.95		238.7				

1-3. PTO SPECIFICATIONS

Max.Power(PS)	RPM
150	1800

 **CAUTION**

D-I Marine transmission must be operated within the limit of capacity of marine engine, If not, slip, overheat or breakage of power transmission line can be happened.

If any questions, contact with D-I Industrial Co., Ltd.

D-I Marine transmission must not be used for the marine engine which is rotated as clock wise (Reverse rotation) seen from the rear of the engine.

If D-I Marine transmission should be used for the clock wise rotation engine, contact with D-I Industrial Co., Ltd. for consultation.

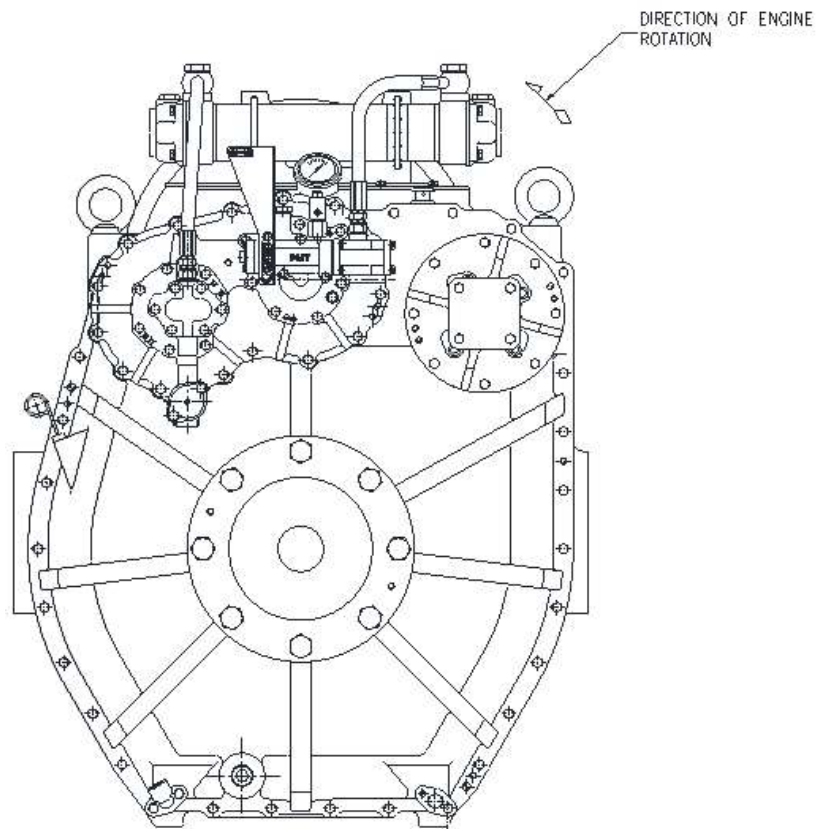

[C.C.W ENGINE]

SECTION 2 – STRUCTURE

2-1. GENERAL

D-I marine transmission consists of five major assemblies. They are input shaft assembly, astern shaft assembly, idle shaft assembly, PTO shaft assembly, and output shaft assembly for the power transmission system, and also there are oil pressure-producing pump assembly, oil cooler assembly, selector valve assembly and valve holder assembly, pump holder assembly for the hydraulic system.

They are the lock-up type in which a marine gear housing is bolted directly to the engine flywheel housing, and the power is transmitted from driving ring which is fitted on the flywheel of engine to the input shaft through a spider with rubber blocks fixed on the input shaft. This system makes easily installation of marine transmission on the engine and the replacement of the rubber block.

IMPORTANT

Torsional responsibility

Torsional vibration analysis can be made by the engine maker or independent consultants. D-I can provide relevant data on the analysis of transmissions supplied by D-I Industrial Co.,Ltd.

The responsibility for ensuring torsional compatibility of the propulsion system rests with the assembler of the drive and driven equipment. D-I has no liability for gearbox noise caused by vibrations or for damage to the gearbox, the flexible coupling or other drive units caused by this kind of vibration.

Users are advised to note that they should refer to instruction manual prior to use D-I products for safe operation.

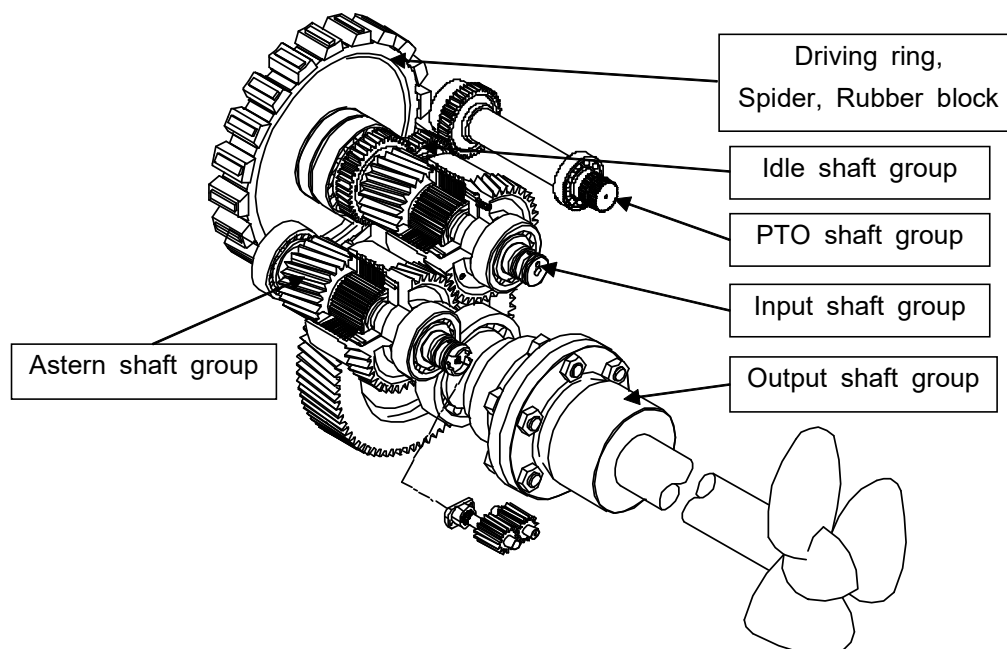

[Fig-1] Marine Transmission Construction

2-2. INPUT SHAFT ASSEMBLY

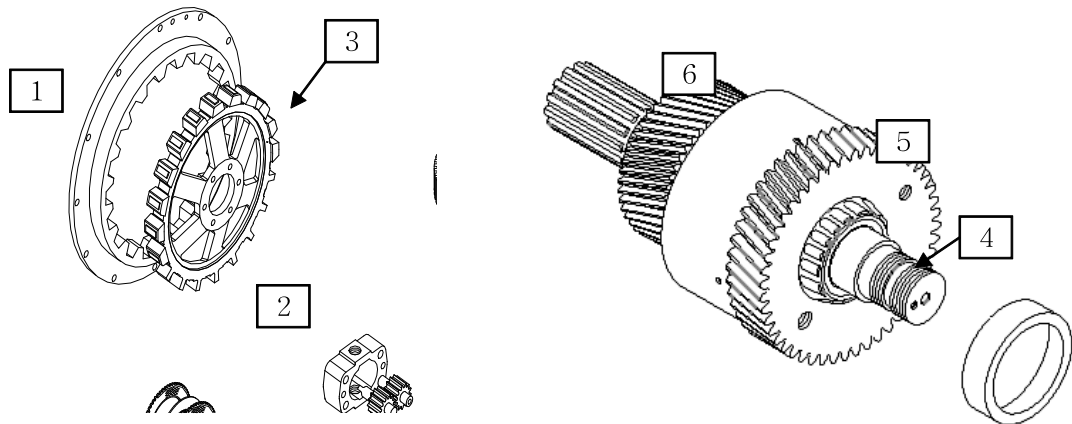

1) Driving ring

The driving ring is furnished with the involute groove on which the rubber block is fixed to transmit power, and is bolted directly to the engine flywheel.

2) Spider

The spider is fixed on the input coupling with reamer bolts, and constructed in a manner that the rubber block can be fixed on it.

3) Rubber block

The rubber blocks are rubber products of involute gear teeth, and reduce rotative vibration of the engine and transmit the power smoothly.

4) Input shaft

The input shaft is connected with the input coupling with a spline, and the ahead clutch housing is shrinkage-fitted to it.

5) Ahead clutch sub-assembly

The ahead clutch sub-assembly consists of a clutch housing, a pinion, a clutch piston, the steel plates with internal gear teeth, the sintered plates with external gear teeth and a back plate.

The steel plates are furnished with internal gear teeth which are engaged with external gear teeth of the pinion, and the external sintered plates are furnished with external gear teeth which are engaged with internal gear teeth of the clutch housing.

The internal steel plates and external sintered plates are assembled alternately with each other, and the pressured oil pushes the clutch piston which actuates the ahead clutch when the lever of the selector valve is shifted to ahead position. Then, the internal steel plates and external sintered plates are stuck fast to each other to transmit the power from the ahead clutch housing to the pinion.

If the lever is shifted to the neutral position, the clutch piston returns to its

original position by the force of a return spring, and thereby oil is discharged from the piston and the clutch is automatically separated.

6) Pinion

The pinion is engaged with the output gear fixed on the output shaft to transmit the power from the ahead clutch housing to the output gear.

2-3. ASTERN SHAFT ASSEMBLY

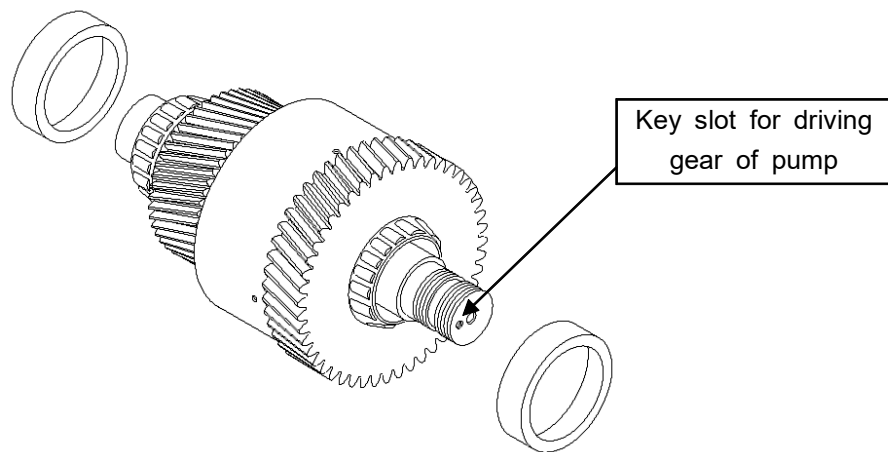

The astern shaft assembly has the same parts as those which the input shaft assembly has, except that the former has no spline in the front and has the hydraulic pump driving device in the rear end.

2-4. OUTPUT SHAFT ASSEMBLY

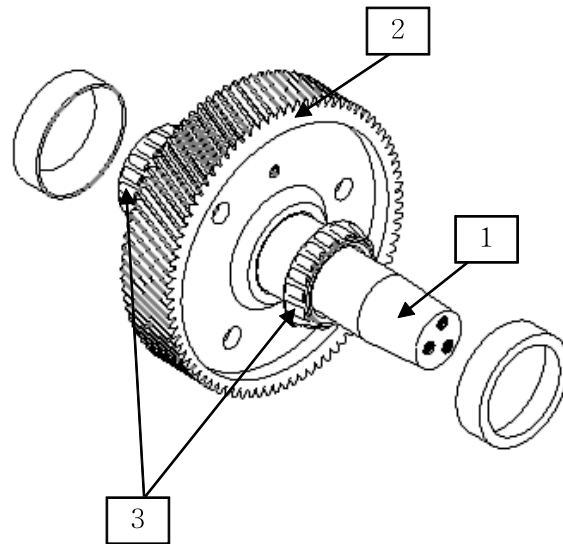

1) Output shaft

The output shaft is supported with two taper roller bearings, and an output gear is shrinkage-fitted thereon. It has an output shaft coupling attached thereto in the rear end.

2) Output gear

The output gear is engaged with the ahead and astern pinion at all time.

3) Taper roller bearings

The taper roller bearings fixed on both sides of the output shaft support the thrust force generated from the propeller during the ahead or astern actuation.

4) Output coupling

The output coupling is connected to the output shaft by means of taper connection and is fixed firmly on it with bolts and a lock washer.

2-5. CASE ASSEMBLY

The case assembly is made of cast iron and consists of a case, a case cover, and a bearing carrier.

2-6. PUMP HOLDER ASSEMBLY

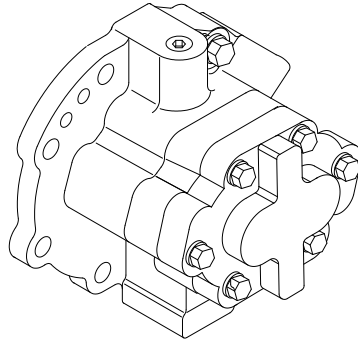

The pump holder is made of cast iron. The hydraulic pump is the circumscribed gear type, and bolted on the pump holder. The pump driving gear is connected by keyed connection way on the end of the astern shaft to be driven and rotated at the same speed as that of engine, but in the opposite direction.

2-7. SECONDARY OIL FILTER

This is attached to the inlet of the ahead holder to re-filtrate oil filtered through the screen filter on the inlet side of the pump before leading it to the bearing carrier.

As it has simple structure, it is very easy to clean by removing the filter cover.

Periodic Inspection : ANNEX I

2-8. SELECTOR VALVE ASSEMBLY

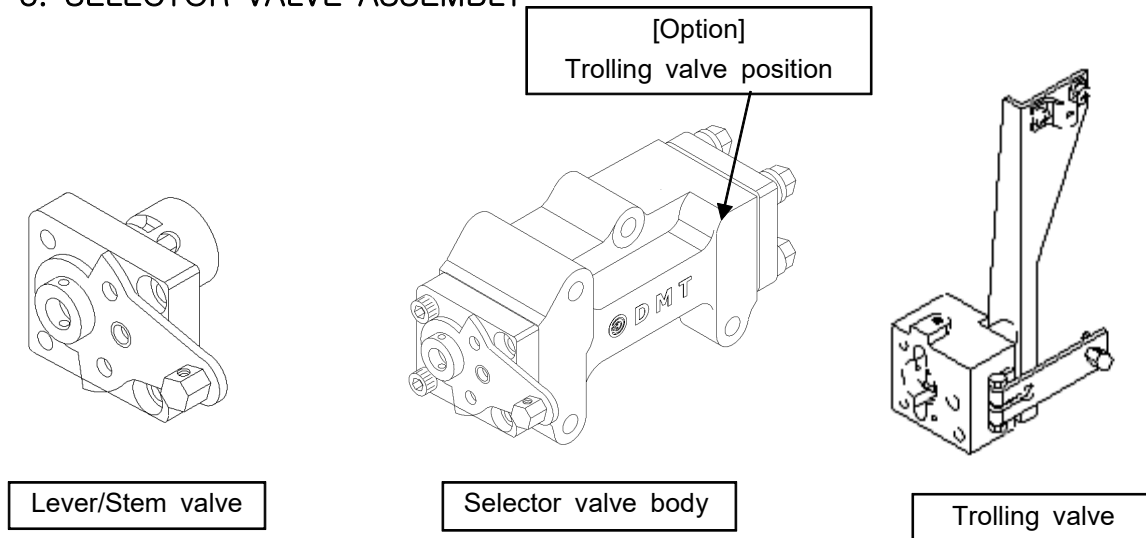

1) Selector valve body

The selector valve body is made of cast iron, and bolted on the valve holder.

2) Valve stem

The valve stem is rotated in the valve body, and has three ports leading oil to the passages for ahead, neutral, and astern position. The pressured oil for actuation of the clutch is led to each clutch through these passages.

3) Selector lever

The lever is fixed on the valve stem with a spring pin, and clutch operation for ahead, neutral, or astern position can be performed by operation of this lever. And it is provided with a proper Control Head to make remote control.

2-9. OIL STRAINER ASSEMBLY

The oil strainer assembly is connected with a suction pipe of the pump inlet side to filtrate oil and fixed on the bottom side of the cover with screws.

Periodic Inspection : ANNEX I

2-10. OIL COOLER

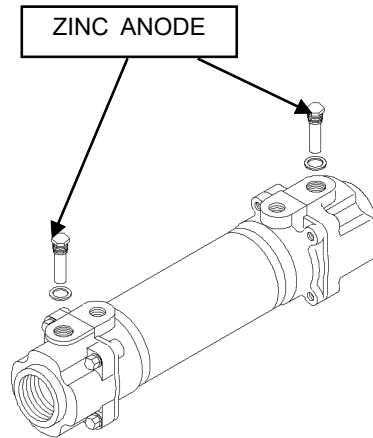

The oil cooler is fixed above the case cover with bolts, and cools the oil supplied from the hydraulic pump before leading it into the secondary oil filter. Oil Cooler contains the alloy (of aluminium and brass) pipe which is strong against corrosion. In addition, zinc anodes are put into the oil cooler.

Periodic Inspection : ANNEX I

2-11. P.T.O SHAFT ASSEMBLY

The P.T.O can take power off engine and enables a hydraulic pump to drive.

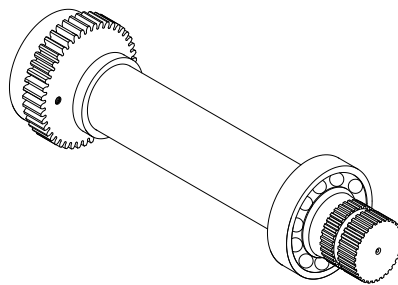

This live P.T.O has 0.98:1 ratio and P.T.O rotates in the same direction and speed as that of the engine.

SECTION 3 – PRINCIPLES OF OPERATION

3-1. OVERVIEW

D-I Marine transmission is operating with the hydraulic pressure and must be operated within the limits of rated load capacity, and has the same capacity and reduction ratio for the ahead and astern actuation. Therefore it can be appropriately used in the application of twin engine system.

The clutches are hydraulic multi-plates types and performed by the hydraulic pressure. The lubrication for the each part is divided into 2 ways, one is lubricated by force and another by scattering.

* Lubrication by force: the input shaft spline, input coupling oil seal, bearings, gears, pinion bush, internal steel plates and external sintered plates, and etc.

* Lubrication by scattering: bearings, pinion gears, output gear.

3-2. DIRECTION OF ROTATION

The input shaft is rotated in the same direction as that of engine, and the output shaft in the opposite direction during ahead actuation but in the same direction during astern actuation.

3-3. POWER TRANSMISSION FLOW

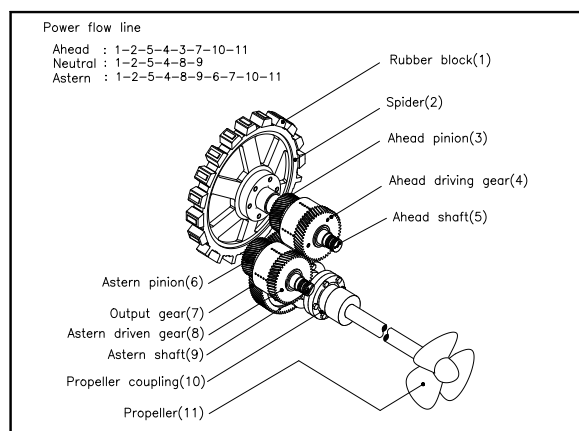

[Fig-1] MARINE TRANSMISSION POWER FLOW

[Fig-2] Marine Transmission Power Flow

1) Neutral position

① The power is transmitted from the driving ring bolted on the flywheel of the engine to the spider with the rubber blocks attached.

② The spider transmits the power to the input shaft via the input coupling, and the ahead clutch housing, which is shrinkage fitted to the input shaft, is rotated simultaneously.

③ The internal gear teeth of the ahead clutch housing are engaged with the external gear teeth of the external sintered plates for the ahead clutch actuation, and these sintered plates is rotated simultaneously. And, the external gear teeth of the ahead clutch housing are engaged with those of the astern clutch housing, and the internal gear teeth of the astern clutch housing are engaged with the external gear teeth of the external sintered plates for the astern clutch actuation, so that the astern clutch housing and the external sintered plates for astern actuation are rotated in the opposite direction of the engine.

In the neutral position, all the parts being rotated of the marine transmission do not transmit any power.

2) Ahead position

① In the ahead position, the high pressure oil which is led from the selector valve pushes the clutch piston of the ahead clutch, and the clutch plates in the ahead clutch housing are stuck fast to each other.

② The internal steel plates begin to rotate in the same direction as that of the engine.

③ The internal gear teeth of steel plates are engaged with the external gear teeth of the ahead pinion, and thus the pinion is rotated in the same direction as that of the external sintered plates at the same speed.

④ At this point, the output gear engaged with the pinion is rotated in the opposite direction of the engine. And the power is transmitted to the propeller through the shrinkage-fitted output shaft and the output gear.

3) Astern position

① In the astern position, the external sintered plates in the astern clutch housing, which is rotated at the same speed as the engine and in the opposite direction up to now, is stuck fast to the internal steel plates.

② The internal gear teeth of steel plates are engaged with the external gear

teeth of the astern pinion, and thereby the astern pinion is rotated in the same direction as that of the external sintered plates at the same speed.

③ At this point, the output gear engaged with the astern pinion is rotated in the same direction as that of the engine.

④ And the power is transmitted to the propeller through the shrinkage-fitted output shaft and the output gear.

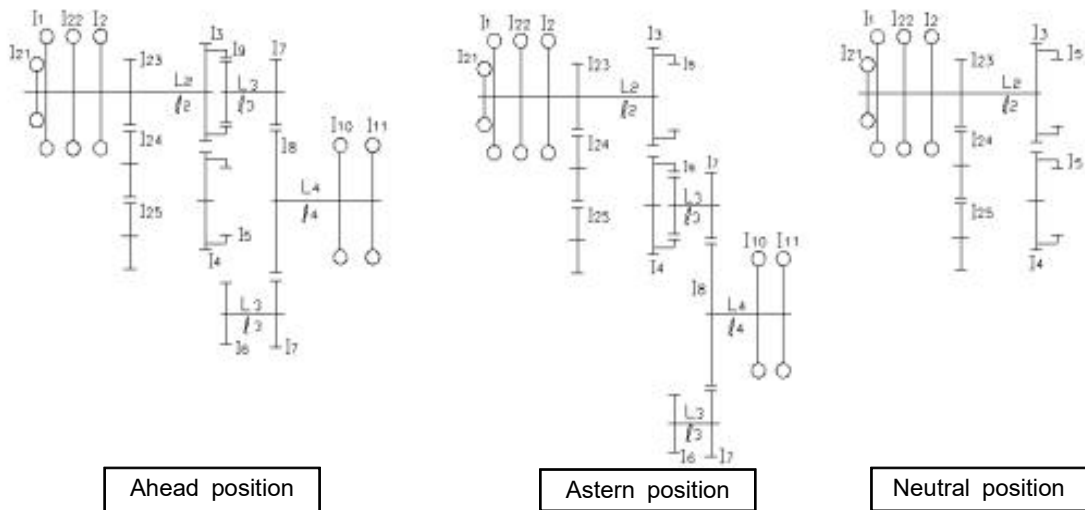

[Fig-3] Marine Transmission Power Flow

SECTION 4 – HYDRAULIC SYSTEM

4-1. OVERVIEW

The hydraulic system is shown in Fig.4. The oil contained in the marine transmission flows into the pump through the oil strainer, and high pressure oil that is discharged from the gear pump is led to the selector valve body through the oil cooler, the secondary oil filter and the manifold. And then, the oil is regulated to the determined pressure by means of the oil pressure regulating valve before being led to the valve stem for clutch actuation.

By changing the oil direction of the valve stem, the oil is led to either the ahead or astern actuation clutch.

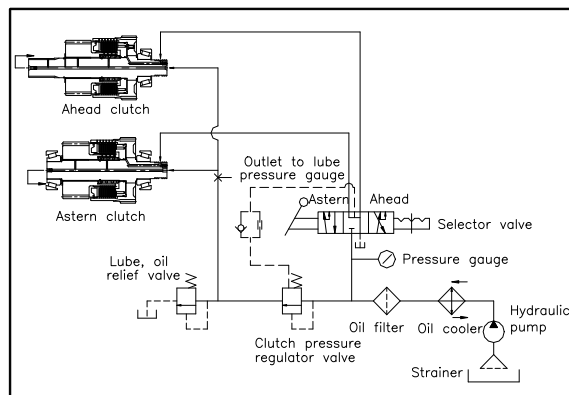

[Fig.2] HYDRAULIC SYSTEM

[Fig-4] Hydraulic System

4-2. SELECTOR VALVE ASSEMBLY

1) Flow of the pressured oil by operation of the selector valve is shown in [Fig.5].

The pressured oil discharged from the gear pump is led to the direction of the arrow "P" in [Fig.6], and then into the hole of the valve stem.

2) When the selector valve is operated for ahead or astern position, part of the oil is led to the rear surface of the clutch piston to actuate the clutch, and another part of it is led to the oil pressure regulating piston through the orifice of a check valve to raise the oil pressure to the determined pressure gradually. And the rest of the oil by continuous discharge from the hydraulic pump, pushes the oil pressure regulating valve and flows through the passage "L" into the lubricating oil passage to forced-lubricate respective parts with pressure regulated by means of the lubricating oil pressure regulating valve.

3) When the selector valve is shifted toward the neutral position, the return spring of the clutch returns the clutch piston to disconnect the clutch, and the piston is also returned to lower the pressure down.

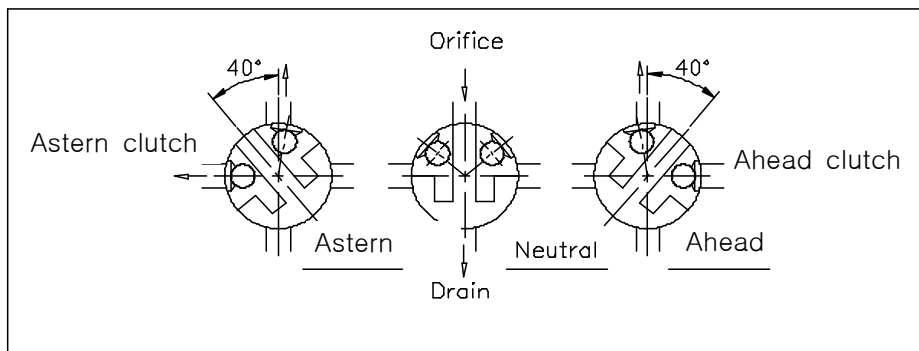

[Fig-5] Oil Passage of Selector Valve

[SEC. A-A of Fig-6]

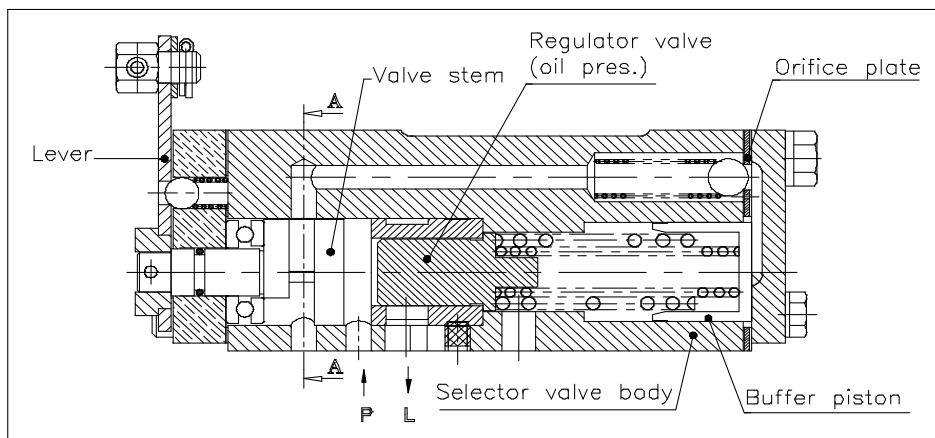

[Fig-6] Selector Valve Ass'y

SECTION 5 – INSTALLATION

Installation of marine transmission has an important effect on the function and performance of the marine transmission.

GAUGE / TOOL	SPEC.	REMARK
DIAL GAUGE		
MAGNET BASE		
THICKNESS GAUGE		
WRENCHES		



The key, which is used for starting a marine engine, should be pulled off before installing Marine transmission to the Marine engine.

5-1. Check point before installation

- 1) D-I marine transmission is supplied to customers without oil. Thus, before operation, make sure that the marine transmission is fed with oil SAE#30 and check the oil amount with oil gauge (about 40 liter)

5-2. Installation

The alignment between the engine and the marine transmission is the most important factor for normal performance and life extension.

1) Bedrail

Use the engine bedrail made of well-dried rigid wood or steel.

If the engine bedrail is not rigid, the alignment will be deviated due to the vibration of the engine or other influence.

2) Supporting

The support brackets for the marine transmission have to fix on the engine bedrail firmly like the engine mounting.

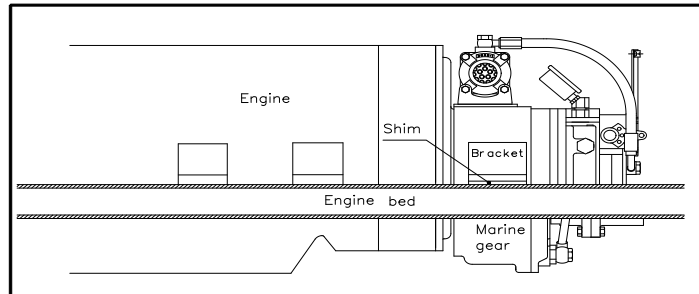

! CAUTION

Bolts for Housing and Brackets of marine transmission should be tightened firmly. If not, a noise, vibration or breakage of housing can be occurred.

3) Alignment

The alignment between marine transmission's output shaft coupling and the propeller shaft coupling should be aligned well and the allowable deviation is as indicated in the following figures :

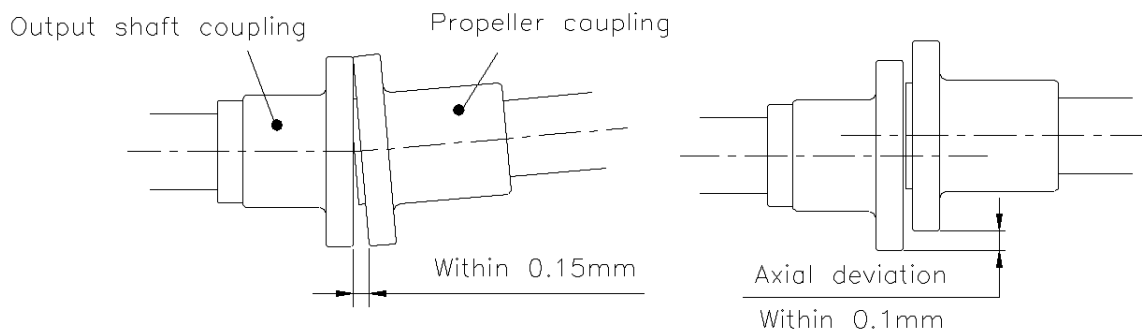

 **CAUTION**

The alignment must be made only when the ship is afloat, not in a dock. In addition, in case of a wooden ship, periodic check should be made every one or two months since the engine bedrail may be bend up to about six months after initial installation, and also a FRP or steel ship must be checked periodically.

SECTION 6 – OPERATION

6-1. Preparations for operation

- 1) Check the whole parts of marine transmission and if the bolts, nuts, etc. are loosened.
- 2) Check the oil level with oil level gauge and neutral pressure
 - 2-1) Check if the neutral pressure(1~5 kgf/cm²) is formed within 30 seconds at idle RPM after the engine starts up.(If not, just stop the engine and then check relevant parts)
 - 2-2) After running the engine at idle RPM for 2~3 minutes, stop the engine and check the oil level immediately.
- 3) Place the selector valve lever on the neutral position before starting the engine.

 CAUTION	Check the oil amount in marine transmission before operation. If the oil is not enough, fill it up with oil.
--	--

6-2. Operation

- 1) Run the engine at engine idle RPM for about 10 minutes for warming-up.
- 2) During 10 minutes warming-up, check on oil leakage, abnormal noise, over-heat, cooling water condition, etc.
- 3) Check the neutral oil pressure as increasing the engine RPM gradually. (The clutch oil pressure is 1~5 kgf/cm² at engine idle RPM in neutral position)
- 4) Check if the operating oil pressure is normal when operating the marine transmission in ahead and astern position.(Refer to 1-2 "Specifications")
When decreasing the engine RPM, the operating oil pressure could be decreased a little bit, however, it is normal.
- 5) The shifting of selector valve lever to ahead or astern position must be taken at 50% of rated engine RPM or under.
- 6) The oil temperature during continuous operation is 50-90°C, but it could be increased a little bit by frequent ahead and astern operations.
- 7) Observe abnormal noises, over-heat, etc. all the time during operation. If abnormal conditions are found, stop the engine and find out the cause of them and then take measures to solve them.
- 8) Be sure to place the selector valve lever on the neutral position before stopping the engine.

- 9) To use emergency screws in an emergency
 In case that the ahead clutch is slipped or not operated, it can be engaged mechanically by emergency measures. The ahead clutch has three screws called emergency screws assembled and it can be engaged by tightening the screws. If the failure is repairable on the spot, repair it correctly as referring to "Trouble shooting". If it is not repairable on the spot, enter the nearest port by using the emergency screws and then repair it.

 CAUTION	Shifting of selector valve lever to ahead and astern position must be taken at 50% of rated engine RPM or under.
--	--

* How to use the emergency screws

- 1) First of all, stop the engine.
- 2) Remove the plug shown in [Fig.7].
- 3) After finding the emergency screws through the hole(covered with the plug) as turning the engine flywheel, tighten the three screws by hexagonal wrench(Below DMT25AL:4mm, Over DMT50A:5mm) to engage the clutch. The screw torque is 130kgf.cm.
- 4) Re-assemble the removed plug

 CAUTION	To use the emergency screws means that the ahead clutch is engaged all the time. Therefore, be careful when the engine starts up because the vessel moves forward once the engine is on. During a sail, the selector valve must be placed on the ahead position and the engine should be operated at 70% of rated engine RPM or under. When using the emergency screws, fill the marine transmission with oil till the oil level comes up to center of astern shaft.
--	---

 DANGER	The vessel should slow down before entering the port and be taken in tow because the astern function does not work while using the emergency screws.
---	--

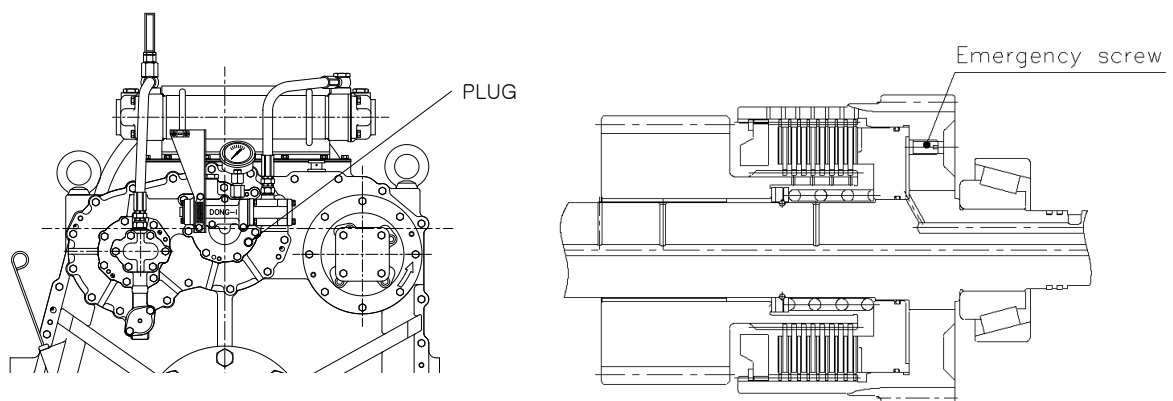

[Fig-7] Position of Emergency Screw

SECTION 7 – PREVENTIVE MAINTENANCE

7-1. General

All the rotating parts of the marine gear are lubricated with oil in the case. The followings are the check points for maintenance of the proper performance :

7-2. Oil

- 1) Use only SAE-API service class SAE#30 engine oil.
- 2) Check the oil level everyday.(Refer to 5-1, Section 5)
- 3) Replace the oil after first 100 hours, and then every 1,000 hours.
 - * If a foreign substance such as water, seawater, etc has come into the marine transmission, overhaul it and clean its part before assembly, and then feed it with new oil.

 CAUTION	Use only SAE-API service class SAE #30 engine oil. Multi-grade oils(SAE#10W, 15W40,etc) MUST NOT be used in D-I marine transmission because they have influence on the coefficient of friction to make the clutch slipped.
---	--

MARINE GEAR Recommended Oil

Name	Manufacturer
Daphne Marine Oil SX30	S-Oil
Delo 1000 Marine 30	GS Caltex
diamond Marine T103(TBN13 SAE#30)	MICHANG OIL IND,CO.,LTD.
Exxmar 12TP30	Esso Oil Co., Ltd
Mobilgard 312(SAE#30)	Mobil KOREA
Shell Gadinia Oil 30	Showa Shell Oil Co., Ltd
Jomo marines D13	Japan Energy Corporation

7-3. Oil filter

Also, disassemble the oil strainer and the secondary oil filter to clean them at the time of oil changing.

7-4. Visual Inspection

Inspect external parts of the marine transmission frequently, and repair it if any defect is found. Particularly, inspect the rubber blocks through an inspecting window of the flywheel housing frequently, and if they are damaged or wear, replace them with new ones.

7-5. Overhaul

The overhaul period of the marine transmission is the same as that of the engine.

If any wear or damaged part is found, replace them according to the followings:

- 1) Replace all of the gaskets, O-rings, and other rubber products in every overhaul.
- 2) Replace the rubber blocks and bearings every 10,000 hours, or earlier if excessive wear or damage is found.
- 3) [Table 1] shows the allowable wear limits of the important parts.

[Table 1]

Parts	Point to be measured	Allowable wear limits	Remedy when limit is excessive
input coupling and input shaft	Spline backlash	0.3	Replacement
pinion and output gear	Gear backlash	0.5	"
clutch housing gear	"	0.4	"
pinion bush and input shaft	clearance	0.2	"
sintered plates and clutch housing	Gear backlash	0.5	"
steel plates and pinion	"	0.5	"

(Unit : mm)

Replace the worn-out parts in case of over the allowable wear limits. If too prolonged operation is expected to do the subsequent overhaul, it is preferable to replace them even if they are within the allowable wear limits.

7-6. Periodic Inspection Table

Periodic Inspection : ANNEX I

SECTION 8 TROUBLE SHOOTING

If something is wrong with the marine transmission, refer to [Table 2].

[Table 2].

Symptom	Cause	Remedy
1. Low main oil pressure	1) Oil strainer clogged 2) Secondary oil filter clogged 3) Oil pressure regulating piston stuck in the control valve 4) Seal damaged or worn 5) Hydraulic pump damaged or worn 6) Remote control faulty 7) Orifice clogged 8) Clutch oil pressure regulator valve's spring damaged or worn	1) Remove clog and clean 2) " 3) " 4) Replacement 5) " 6) Adjustment 7) clean it 8) Inspect length of spring and replace it if necessary
2. No oil pressure	1) Oil level low 2) Hydraulic pump defective 3) Air leak on suction side of pump	1) In case of oil leakage, replace of the components such as gaskets, oil seals, etc. which cause oil leakage and fill the oil 2) Replace hydraulic pump 3) Correct cause of air leak
3. High main oil pressure	1) regulating valve stuck	1) Remove clog and clean
4. Low Lubricating oil pressure	1) Lubricating oil pressure regulating valve operated poorly	1) Remove clog and clean
5. Over-heat	1) Clutches slipping 2) Excessive oil level 3) Bearing damaged 4) Defective rotating part	1) Disassemble marine transmission and check of clutch plates 2) Regulation of oil level 3) Overhaul marine transmission 4) Refer to Item 6
6. Rotating parts defective	1) Clutch plates stuck 2) Pinion bush stuck 3) Both thrust washers of pinion stuck 4) Clutch piston's returning spring is damaged or broken	1) Disassemble of clutch ass'y and replace clutch plates 2) Disassemble and replace 3) Disassemble and replace thrust washers 4) Disassemble and replace of spring
7. Improper Shifting of ahead / astern	1) Clutch plates stuck 2) defective Remote controller 3) Clutch piston's return spring is damaged or broken	1) Disassemble of clutch ass'y and replace clutch plates 2) Adjust and replace remote controller 3) Refer to Item 6-4).
8. Abnormal noise	1) Gear teeth or spline damaged worn 2) Bearing damaged 3) Rubber blocks damaged or worn 4) Bolts or nuts loosened or removed	1) Disassemble and repair or replace 2) Disassemble and replace 3) " 4) Secure tightening

SECTION 9 – DISASSEMBLY AND ASSEMBLY

9-1. Disassembly

Check the marine transmission for oil leakage or abnormal noise before disassembly.

 CAUTION	<p>Assembly and Disassembly should be performed in a place where there is no dust and foreign matter, etc.</p> <p>Don't assemble or disassemble marine transmission when raining or high percentage of humidity.</p> <p>The following pictures, which is used to help you understand, is for DMT50A. Thus, for other models, please refer to parts list and perform the assembly or disassembly accordingly.</p>
--	--

TOOLS	SPEC.	REMARK
Wood Rags Washer Combination Wrench sets Torque Wrenchs Zig for Shim Adjustment Bearing Puller Bearing Heater Snap Ring Pliers Impact socket sets		

1) Disassembly of the marine transmission

- ① Drain all the oil from hydraulic systems.
- ② Disconnect all the connecting parts.
- ③ Disconnect the output shaft coupling and the propeller shaft coupling to provide a sufficient space for easy removing of the marine transmission.
- ④ Remove the marine transmission from the engine, but do not remove the driving ring unless replacement of parts is necessary.

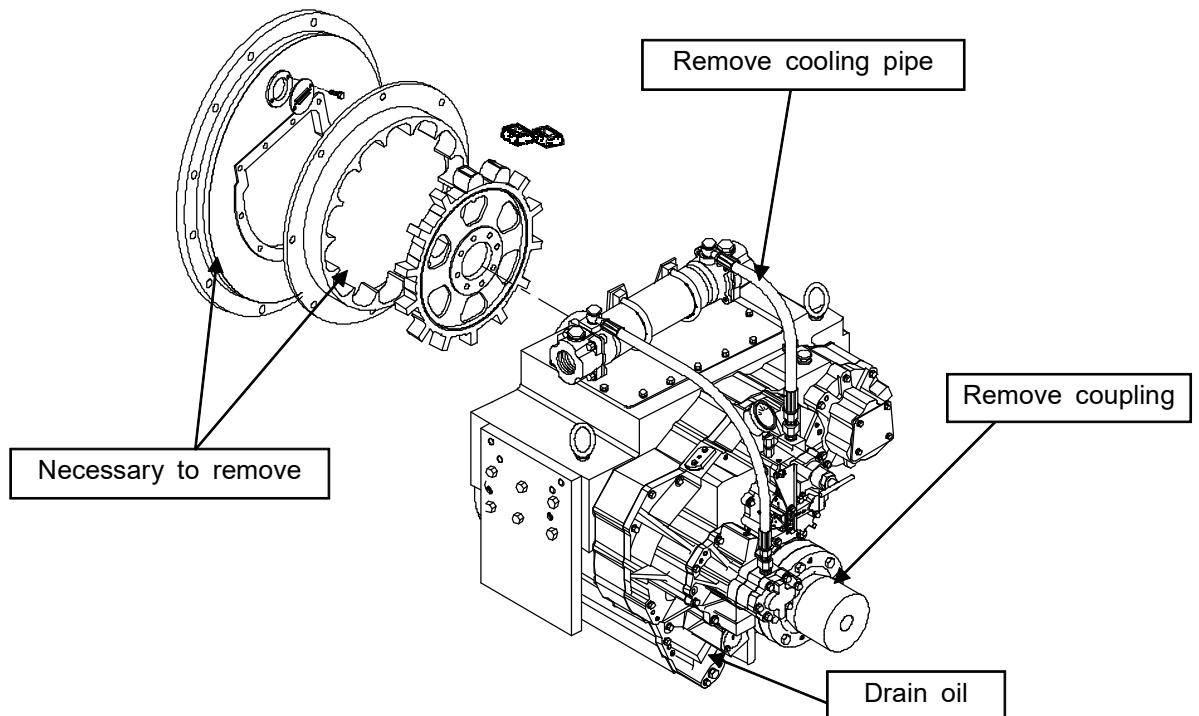

2) Case disassembly

- ① Place the marine transmission on a rigid wooden bed with its input side down so that the spider can be easily rotated.
- ② Remove the manifold(pump holder and the valve holder) fixed on the bearing carrier
- ③ Remove the hydraulic pump
- ④ Remove the bearing carrier fixed on the cover by pulling bolts, and then remove outer case of the bearing fixed on the bearing carrier.
- ⑤ Remove the input shaft assembly and the astern shaft assembly.
- ⑥ Remove the output shaft coupling, and then the case cover by pulling bolts .
- ⑦ Remove the input coupling.

 CAUTION	<p>Ⓐ Do not remove the input coupling, unless it is needed to replace.</p> <p>Ⓑ When disassembling the case, take care not to damage or lose the clearance adjusting shim for the bearings of the input, astern and output shafts for re-assembly.</p> <p>Ⓒ As the clearance may be changed according to wear of the thrust washers or replacement of the bearings, adjust the shim according to description of Item 9-3 at the time of assembly.</p>
---	---

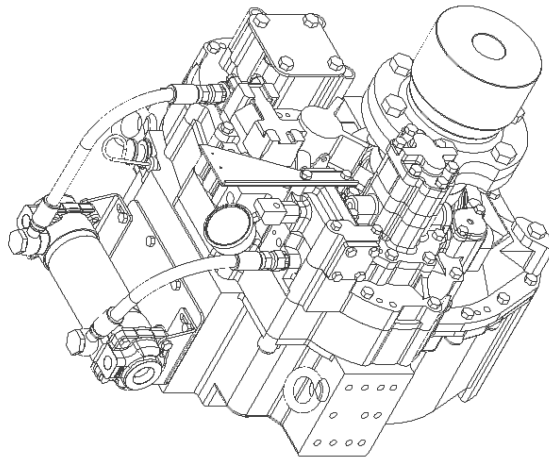

3) Input shaft assembly

- ① Remove the retainer placed in the front, and then the thrust needle bearing, the pinion gear and the thrust needle bearing in order.
- ② Remove the snap ring, and then the back plate to support clutch plates the external sintered plates, and the internal steel plates in order.
- ③ Press the spring toward the clutch piston, and remove the retainer placed in the middle of the input shaft, and then the spring support and the return spring.
- ④ Strike the spline portion of the input shaft against a wooden bed to remove the clutch piston.

 CAUTION	Do not use a steel bed as the shaft may be damaged
---	---

- ⑤ remove four seal rings installed on the shaft end

 CAUTION	Be careful not to break Rings (oil seal)
---	---

- ⑥ Do not remove the bearing on the rear side unless replacement is necessary.

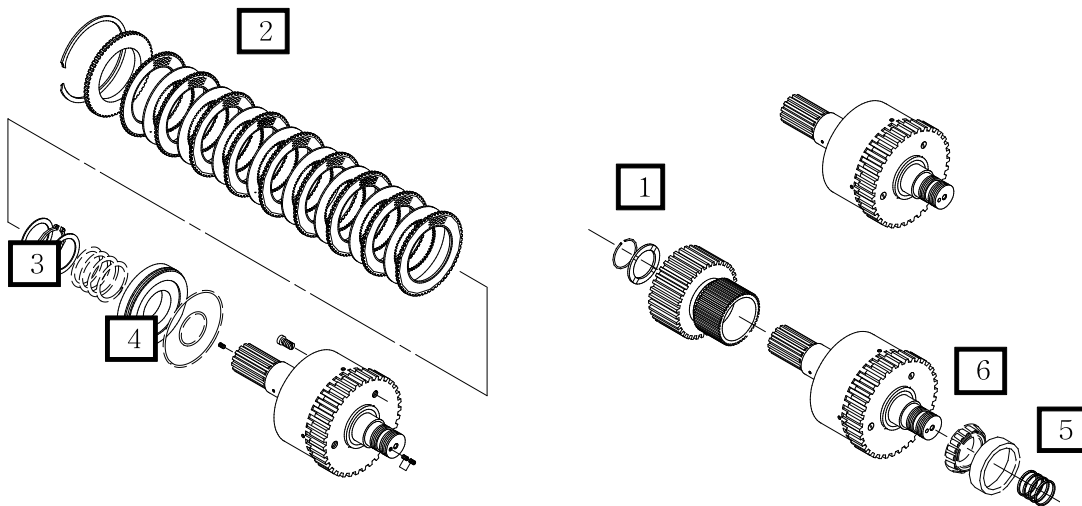

Check Point

☞ [Refer to Table-1]

4) Astern shaft assembly

- ① Remove the taper roller bearing installed in the front of the astern shaft assembly by a bearing puller.
- ② The rest of the removing process is the same as process of the the input shaft assembly.

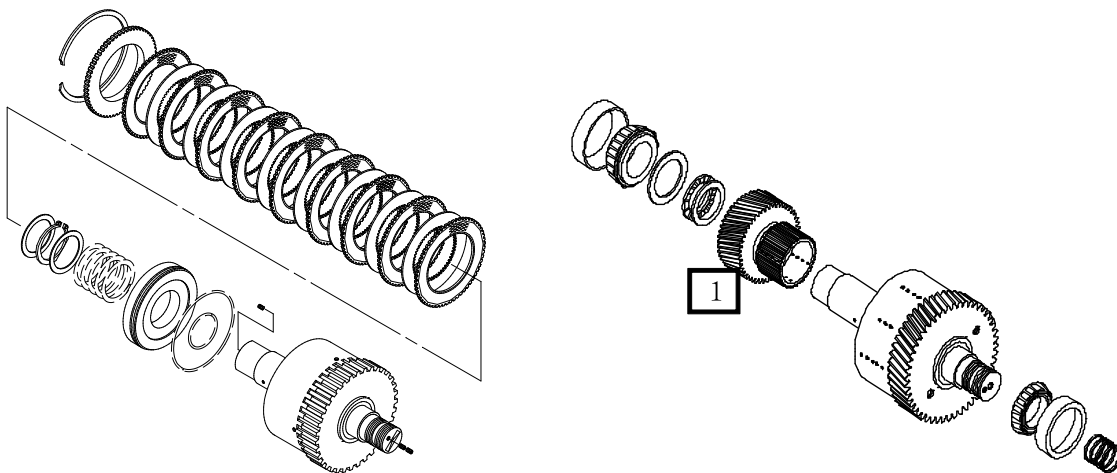

Check Point

☞ [Refer to Table-1]

5) Output shaft assembly

- ① Do not remove the taper roller bearings installed in both sides end of the output shaft unless replacement is necessary.
 - * Do not remove the ahead and astern clutch housings and the output gear as

they have been shrinkage-fitted to the shaft.

 CAUTION	<p>Ahead (Astern) Clutch Housing and output gear is shrinkage-fitted to the each shafts. Thus, it is impossible to disassemble. Do not try to disassemble.</p>
--	--

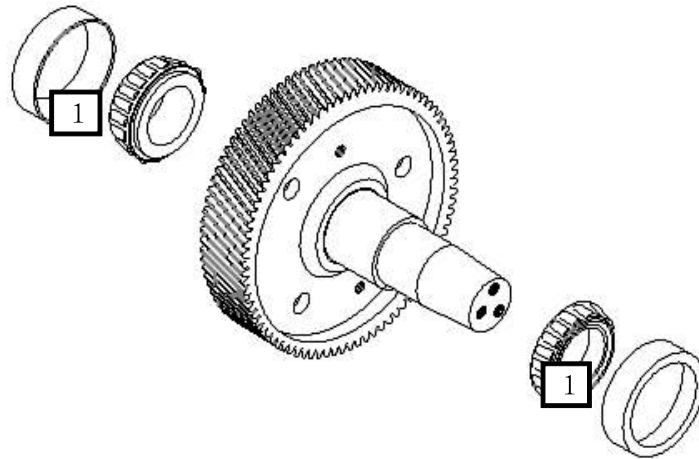

Check Point

☞ [Refer to Table-1]

6) Spider disassembly

Do not remove the spider unless replacement is necessary.

7) Selector valve body disassembly

- ① Remove the hexagonal socket screws, and remove the cover spring pin, lever, selector valve, thrust bearing, O-ring, spring and ball.
- ② Remove the screw, and remove the piston cover, orifice plate, oil pressure regulating piston, springs oil pressure regulating valve, ball, spring and remove the set screw and sleeve.

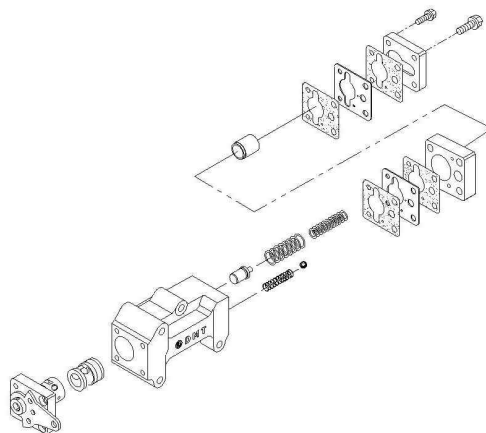

Trolling Valve(Optional)

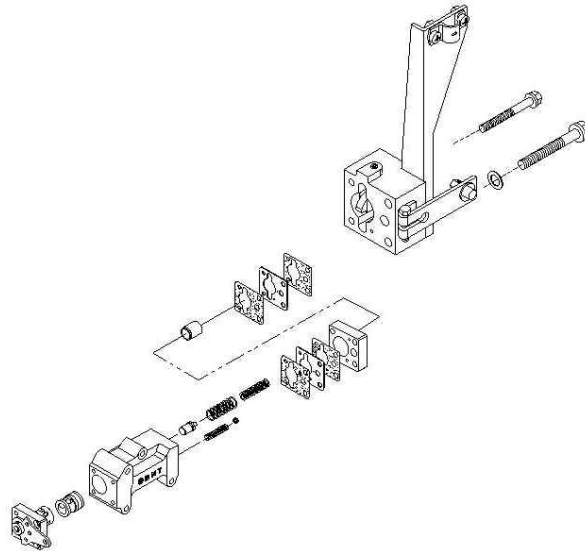

Check Point

☞ [Refer to Table-1]

9-2. Assembly

Assembly shall be performed in the reverse order of disassembly. Clean all the parts so that there should be no dust or metal chip, etc., in the marine transmission before assembly, and observe the followings :

- 1) Replace the parts which cause oil leakage.
- 2) Replace the sliding surface of the bearing discolored or excessively worn out, if it produces an abnormal noise.
- 3) Replace the worn out parts over the allowable wear limits.
- 4) Grease on such rubber parts as O-rings before assembly.
- 5) Replace the gaskets with new ones.
- 6) Check and confirm whether degree of bent of the lock washer is normal before assembly.
- 7) The followings are precautions for assembly of the clutch :
 - ① Before assembling the clutch, check whether the clutch piston, input shaft, or astern shaft where the O-rings are to be seated has a sharp edge and grease them.
 - ② Install the external sintered plates and the internal steel plates alternately in order from the clutch piston side as shown in [Fig 7].
 - ③ Ensure that the snap ring supporting the back plate is firmly seated in its groove before assembling the marine transmission.

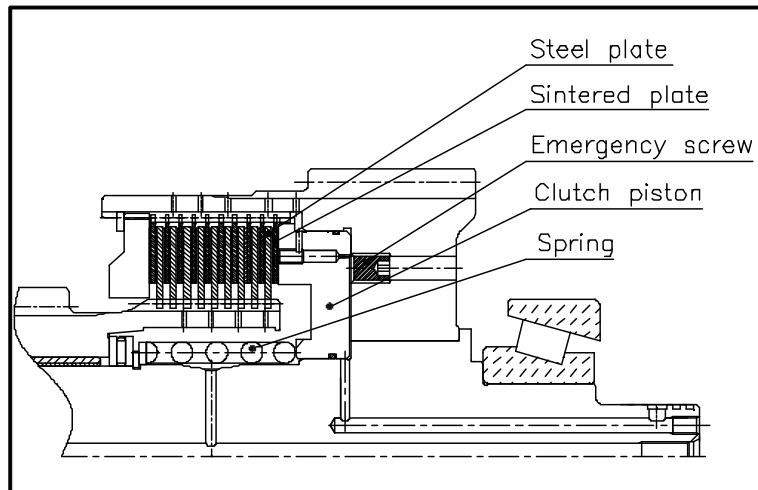

8) Specified torques for screws and nuts

① The specified torque for the screws and nuts are indicated in [Table 3] :

Classification	M5	M6	M8	M10	M12
Hex head cap Screws & nuts		0.5 - 0.8	1.1 - 1.3	2.2 - 2.6	3.9 - 4.5
Hex socket head cap screw	0.6 - 0.7	1.1 - 1.2	2.6 - 3.0		

(Unit : kg · m)

9-3. Adjustment of shim

Adjust the clearance of the taper roller bearings supporting the input, astern and output shafts with a shim as illustrated in [Figs.10 and 11].

- 1) Adjustment by shims of the input and astern shafts; adjust the axial clearance to be $0 \sim 0.05$ pushing the rear bearing toward the front bearing.
- 2) Adjustment by shims of the output shaft; adjust the axial clearance to be $0 \sim -0.05$ in the same manner as the above.



- Ⓐ The shim adjustment should be made very accurately.
- Ⓑ Too small clearance may cause faster wear of the bearings and rise of the oil temperature (over-heat), and too large clearance may cause abnormal wear of the manifold, oil leakage from the oil seals, abnormal wear of the gear, etc.

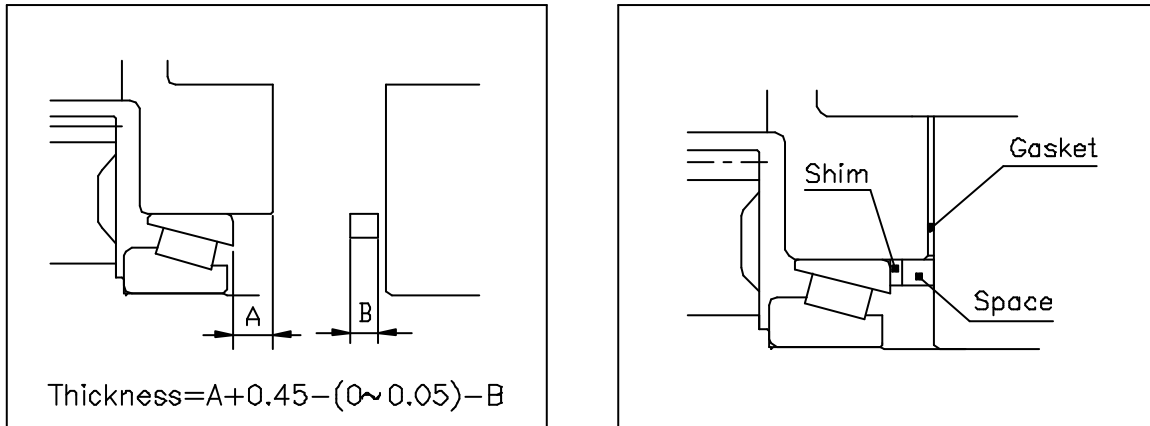

[Fig-10] Input and Astern Shafts

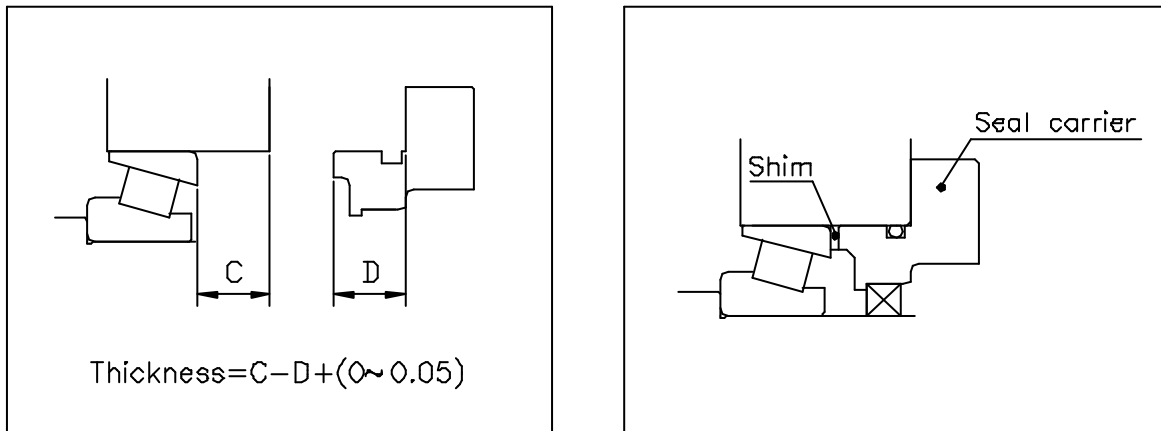

[Fig-11] Output Shaft

! CAUTION

1. The shim adjustment should be made with the special tools that are made according to the drawings provided.
2. D-I Industrial Co., Ltd. will provide you with drawings that are needed to manufacture special tools for the shim adjustment. Refer to the drawing lists attached and contact with D-I Industrial Co., Ltd. for drawings of special tool for the shim adjustment.

OPTION Live P.T.O.

[CONSTRUCTION]

As Live P.T.O is equipped in the this marine transmission, this can drive a hydraulic pump with SAE B or SAE C type.

As an option, connector coupling, pinion coupling and pump attachment plate are supplied with this marine transmission.

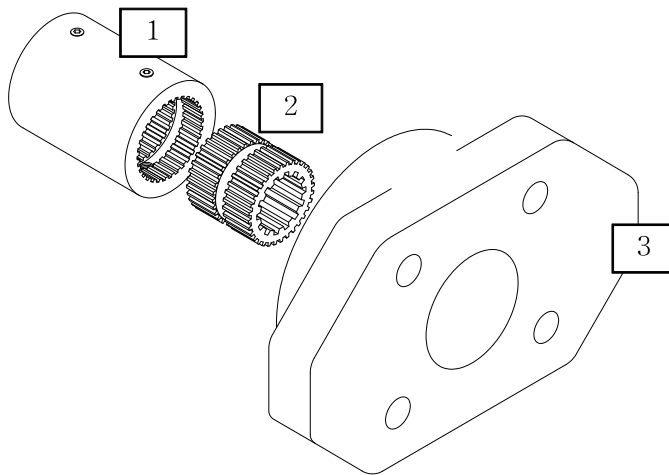

1) Connector coupling

The connector coupling connects PTO shaft with pinion coupling by a spline and transmits a power of a shaft of PTO to pinion coupling.

2) Pinion coupling

Outer spline on the pinion coupling is engaged with inner spline of connector coupling. As inner spline (a key) in the pinion coupling is engaged with shaft of hydraulic pump, this can drive the hydraulic pump.

※Various connector couplings are available according to type of shaft of hydraulic pump.

3) Pump attachment plate

Pump attachment plate where a hydraulic pump is attached is divided into 3 types according to a guide of hydraulic pump and spec of tap.

For details, please get in touch with D-I Industrial Co., Ltd.

HOW TO DISASSEMBLE OUTPUT COUPLING

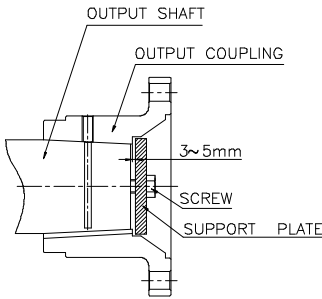
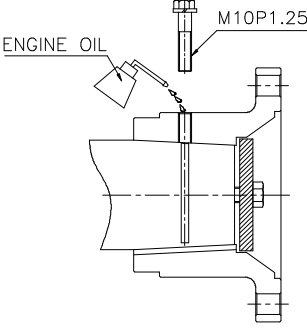
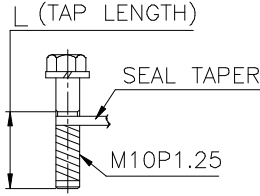
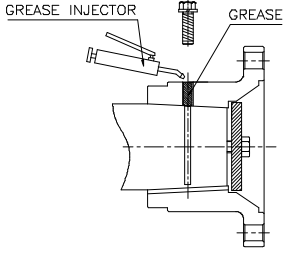
NO	FIGURE	INSTRUCTION
1		<p>1) Assemble the support plate as figure. If not, people might get hurt by the output coupling which might come out suddenly by the hydraulic pressure.</p>
2		<p>1) Pour oil into the hole on the output coupling and then screw the bolt in two or three times to push the oil into the hole.</p>
3		<p>1) Get the bolt wound by seal tape to prevent the oil inside output coupling from leaking out.</p> <p>※Screw Length(L) : 45mm over</p>
4		<p>1) Pour grease into the hole on the output coupling to prevent the oil inside output coupling from leaking out.</p> <p>2) Screw the bolt with seal tape into the hole rapidly to make a pressure inside output coupling.</p> <p>3) Disassemble the output coupling.</p>
<p>[CAUTION] In case the output coupling is not off by above procedure, try above procedure two or three times.</p>		

ANNEX I

PERIODIC INSPECTION TABLE

○ Check, ⊙ Exchange

	NAME	Check / Exchange (year)				Parts to Using	Remark
		1	3	5	10		
M A R I N E G E A R B O D Y	*Gasket, paper				⊙	Cover, Case, Holder etc.	
	*Gasket, copper				⊙	Drain/Magnet Plug etc.	
	*O Ring				⊙	Screen/Secondary Filter Air Breather Ass'y etc.	
	*Seal, oil				⊙	Input Coupling, Output Shaft	
	Ring, oil Seal		○		⊙	Input/Astern Shaft	Wear, Breakage
	Spring		○		⊙	Selector Valve Regulator Pressure etc.	
	Plate (sintered/steel)		○	○	⊙	Clutch houding	Wear, Taken off ,Reform
	*Ring, external				⊙	Input/Astern Shaft	
	Washer, thrust			○	⊙	Input/Astern Shaft	Wear, Damage, Taken off
	Washer, thrust bearing Bearing, thrust needle			○	⊙	Input/Astern Shaft	Wear, Damage, Taken off
	Bush, pinion			○	⊙	Input/Astern Shaft	Wear, Damage, Taken off
	Bearing, taper			○	⊙	Input/Astern/Output Shaft	Wear, Damage, Taken off
	※Magnet Plug					Cover	
	※Oil(SAE#30)						See at 22 page
	※Screen Filter		⊙	⊙	⊙		Breakage, Reform
※Secondary Filter		⊙	⊙	⊙		Breakage, Reform	
P U M P	*Gasket, pump/plate					BODY, pump	
	Bush, pump			○		Plate, pump Cover, pump	Wear, Damage, Taken off
	Pump Ass'y			⊙	⊙		
C O O L E R	*Gasket, paper					Cover, cooler	
	*Gasket, copper					Bolt, union	
	Zinc Anode						Every 6 month to exchange

MARK : The parts, which are marked, should be replaced with new ones once marine transmission is disassembled and assembled.

※MARK : The parts, which are marked※, are recommended to be cleaned when oil replacement (Replace oil after first 100hours and then every 1000hours)

1. REGULAR INSPECTION (EVERY 5 YEARS)

- Inspect and check marine transmission after disassembling.
- Refer to above table for the parts that need to be replaced.

2. OVERHAUL OF MARINE TRANSMISSION (EVERY 10 YEARS)

- Inspect and replace parts after disassembling the marine transmission.
- Refer to ANNEX II for overhaul parts.

ANNEX II

PARTS ORDER SHEET

Fill out the blanks below and get in touch with distributor						DATE		
COMPANY								
NAME								
ADDRESS								
TEL.				FAX.				
PARTS ORDER LIST								
MODEL						Gear Ratio		
						Serial No.		
ENGINE		HP/ rpm		Installation date				
No.	NAME	PARTS NO.	Q.TY	No.	NAME	PARTS NO.	Q.TY	
REMARK								

ANNEX III

WARRANTY LETTER

The marine transmission, which D-I Industrial Co.,Ltd. manufactures, is guaranteed to have a good operation in case that D-I Marine Transmission is operated according to the instructions mentioned in the D-I marine Transmission manuals. D-I Industrial Co.,Ltd. warrants D-I Marine Transmission as follows.

1. SCOPE OF WARRANTY

Warranty is limited to repair or supply with new one against D-I Marine transmission or its parts which is occurred by defective materials or workmanship within warranty period.

2. WARRANTY PERIOD.

D-I Industrial Co.,Ltd. warrants against defective materials or workmanship for a period of twenty-four(24) months from the date of original shipment by D-I Industrial Co., Ltd. to original customer or twelve(12) months from the first sea trial, whichever occurs first.

3. WARRANTY NON EFFECTIVE

D-I Industrial Co.,Ltd. does not warrant

- 1)The parts that are not produced by D-I Industrial Co.,Ltd. or genuine parts which are lost.
- 2)The cost or the breakdown that is occurred for repairing before contacting with D-I Industrial Co.,Ltd.
- 3)The breakdown which is occurred due to any modification to D-I Marine Transmission or its parts without the prior to consent of D-I Industrial Co.,Ltd.
- 4)The breakdown that is occurred due to that the customers do not keep the right handling, operation, periodical maintenance and storage way mentioned in the instruction manuals.
- 5)Consumable parts such as gaskets, packings, tubes and other similar ones.
- 6)The breakdown that is occurred due to the customer's negligence, faulty maintenance. Misuse or non observance of recommended or operation instructions.
- 7)The breakdown caused by using products at over rated power.
- 8)The breakdown caused by other application (other than propulsion of ship) without approval of D-I Industrial Co.,Ltd.
- 9)The breakdown caused by negligence of corrosion protection.
- 10)The breakdown caused by torsional vibrations.

4. OBLIGATION OF USERS.

- 1)D-I Marine Transmission should be inspected and repaired according to the instructions mentioned in the manuals.
- 2)Use of unsuitable parts, inspection or repair can cause a fatal damage. In case that D-I Transmission should be repaired in a workshop, contact CS team of head office or use a workshop that is appointed by D-I Industrial Co.,Ltd.

5. WARRANTY REPAIR

- 1)This warranty letter is accompanied D-I Marine Transmission and is effective with signature of D-I Industrial Co.,Ltd.
- 2)Users should submit this warranty letter to warranty repairman when warranty repair or periodic inspection is performed.

6. D-I Industrial Co.,Ltd. does have no obligation to apply new specifications to the D-I Marine Transmission that was supplied before changing specifications.

7. WARRANTY SUCCESSION

In case that owner is changed because D-I Marine Transmission is resold or contributed to the other customer within warranty period, D-I Industrial Co.,Ltd. warrants the rest of warranty period. In order to do that, this warranty letter should be accompanied with D-I Marine Transmission.

D-I INDUSTRIAL CO.,LTD.

The contents of this manual can be modified without prior notice for the improvement of quality.



FACTORY : (52781) 13, Namgang-ro
1367 beon-gil, Jinju-si,
Gyeongnam-do, Korea

TEL. : +82-55-760-5500

FAX. : +82-55-755-9188

E-mail : dicl@d-i.co.kr

URL : <http://www.d-i.co.kr>

MANU NO. M1709N01DMT



printed: 2017. 09.